

# Type AGF Clutch assembled with Torque Arm End Flange



The combination of an AGF series roller ramp clutch with F3 and F2/F4 flanges provide a unit complete with support bearing and its own integral lubrication system. The units are primarily intended for backstop applications, but can also be used as reciprocating arm on indexing applications.

When used as a backstop, outer race rotation is prevented by cam bolt, which by its shape compensates for misalignment. The bolt must be radially free in its location to avoid loading the bearings, so preferred location is with a slot of width 0.5mm above bolt dia. "C".

Higher torque clutches for 25-35mm shafts can be supplied to special order.

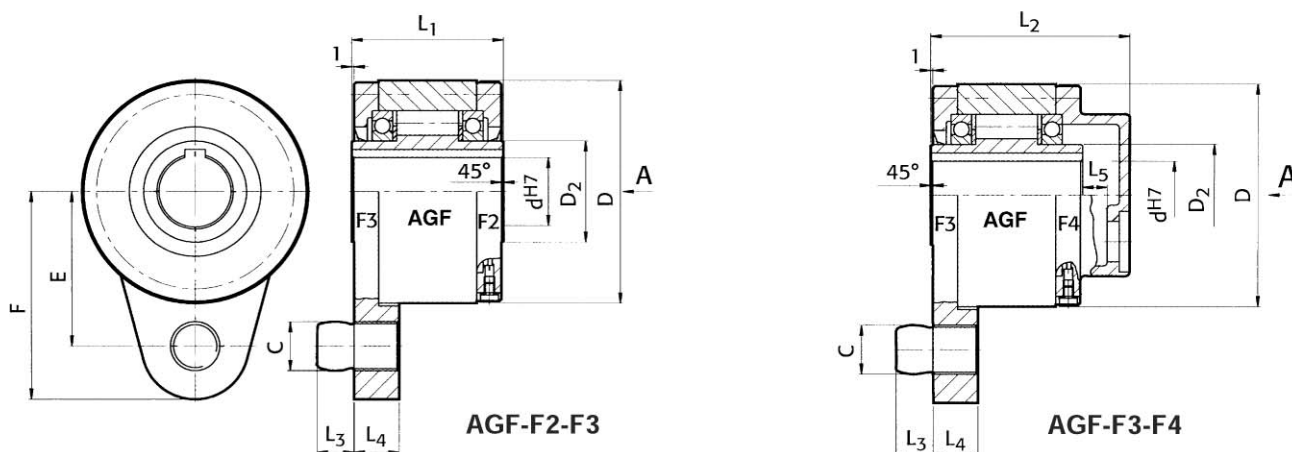

## Dimensions

Clutch Size	Bore mm dH7	Nom Torque Nm <sup>(1)</sup>	Maximum Overrun Speed <sup>(2)</sup>	Dimensions mm											Approx. Weight kg
				D	D <sub>2</sub>	C	L <sub>1</sub>	L <sub>2</sub>	L <sub>3</sub>	L <sub>4</sub>	F	E	L <sub>5</sub>	f	
AGF 12	12	44	3100	62	20	10	42	64	10	13	59	44	6	0.5	1.4
AGF 15	15	100	2800	68	25	10	52	78	10	13	62	47	10	0.8	1.8
AGF 20	20	145	2400	75	30	12	57	82	11	15	72	54	10	0.8	2.3
AGF 25	25	230	1600	90	40	16	60	85	14	18	84	62	10	1.0	3.4
AGF 30	30	400	1300	100	45	16	68	95	14	18	92	68	10	1.0	4.5
AGF 35	35	580	1200	110	50	20	74	102	18	22	102	76	12	1.0	5.6
AGF 40	40	820	850	125	55	20	86	115	18	22	112	85	12	1.5	8.5
AGF 45	45	900	740	130	60	25	86	115	22	26	120	90	12	1.5	8.9
AGF 50	50	1700	580	150	70	25	94	123	22	26	135	102	12	1.5	12.8
AGF 55	55	2100	550	160	75	32	104	138	25	30	142	108	15	2.0	16.2
AGF 60	60	2800	530	170	80	32	114	147	25	30	145	112	15	2.0	19.3
AGF 70	70	4600	500	190	90	38	134	168	30	35	175	135	16	2.5	23.5
AGF 80	80	6800	480	210	105	38	144	178	30	35	185	145	16	2.5	32
AGF 90	90	11600	450	230	120	50	158	192	40	45	205	155	16	3.0	47.2
AGF 100	100	16000	350	270	140	50	182	217	40	45	230	180	16	3.0	76
AGF 130	130	25000	250	310	160	68	212	250	55	60	268	205	18	3.0	110
AGF 150	150	56000	200	400	200	68	246	286	55	60	325	255	20	4.0	214

(1) Max. Torque = 2.5 Nom. Torque for brief periods only. Shaft keyways all to DIN 6885 Sht. 1.

(2) Speeds for oil lubrication. For grease lubrication x0.5.

Clutches and flanges normally supplied unassembled. If a clutch is required to be supplied assembled, please indicate direction of rotation viewed direction "A".

"R" - inner race overruns clockwise direction.

"L" - inner race overruns anticlockwise direction.

### Note:

All clutches are supplied without lubrication, and must be suitably filled prior to operation.

If required, flanges can be supplied separately - Please stipulate flange, clutch size and flange reference:- eg "AGF30F3 flange".